

STUDY OF INNER AND OUTER POCKET CHARACTERISTICS USING AREA ROUGHING METHOD

Edy Suryono

Program Studi Diploma Tiga Teknik Mesin
Sekolah Tinggi Teknologi Warga Surakarta
Email: edysuryono@sttw.ac.id

Y. Yulianto Kristiawan

Program Studi Diploma Tiga Teknik Mesin
Sekolah Tinggi Teknologi Warga Surakarta
Email: yulianto.atw@gmail.com

Emanuel Budi Raharjo

Program Studi Diploma Tiga Teknik Elektronika
Sekolah Tinggi Teknologi Warga Surakarta
Email: emanuelbr@sttw.ac.id

Jonas Andika Siburian

Program Studi Diploma Tiga Teknik Mesin
Sekolah Tinggi Teknologi Warga Surakarta
Email: edysuryono@sttw.ac.id

Jodi Muhammad Fajar

Program Studi Diploma Tiga Teknik Mesin
Sekolah Tinggi Teknologi Warga Surakarta
Email: edysuryono@sttw.ac.id

ABSTRAK

Pocket milling merupakan salah satu proses pengerjaan CNC milling. Penelitian ini bertujuan untuk menganalisis karakteristik *pocket milling* menggunakan *Area Roughing* terhadap kekasaran permukaan dan waktu pemesinan. Metode yang diterapkan adalah dengan penelitian eksperimen terhadap metode *Area Roughing* untuk pengerjaan pocket dalam dan luar. Variabel penelitian meliputi *depth cut* 0,5, 1, 1,5, dan 2 mm, *stepover percent* 40, 50, dan 60%. Pengujian berupa nilai kekasaran permukaan, sedangkan analisa proses pengerjaan adalah waktu selama proses milling. Material benda kerja berupa Aluminium 2024 dan *tool Endmill flat* diameter 12 mm. Hasil yang diharapkan adalah parameter yang memiliki nilai paling optimal terhadap waktu proses pengerjaan dan nilai kekasaran permukaan. Sehingga dapat menjadi panduan untuk proses milling terutama yang menggunakan *Area Roughing*. Hasil pemesinan menunjukkan semakin cepat waktu pemesinan diakibatkan pengaturan semakin besar untuk *depth cut* dan *stepover percent*. Peningkatan waktu pemesinan rata-rata sebesar 28%. Sedangkan nilai kekasaran permukaan akan semakin naik seiring naiknya pengaturan *depth cut* dan *stepover*, yaitu sebesar 17,65% untuk pocket luar dan 18,61% untuk pocket dalam. Nilai kekasaran permukaan hasil pemesinan berkisar antara 2,4-4,8 μm .

Kata kunci: *pocket milling, area roughing, depth cut, stepover percent*

ABSTRACT

Pocket milling is one of the CNC milling processes. This research aims to analyze the characteristics of pocket milling using *Area Roughing* on surface roughness and machining time. The method applied is experimental research on the *Area Roughing* method for working on inner and outer pockets. Research variables include *depth cut* 0.5, 1, 1.5, and 2 mm, *stepover percent* 40, 50, and 60%. The test is in the form of surface roughness value, while the analysis of the machining process is the time during the milling process. The workpiece material is 2024 aluminum and a flat endmill tool with a diameter of 12 mm. The expected result is the parameter that has the most optimal value for the processing time and surface roughness value. So it can be a guide for milling processes, especially those that use *Area Roughing*. The machining results show that the faster machining time results from larger settings for *depth cut* and *stepover percent*. Average machining time increase of 28%. Meanwhile, the surface roughness value will increase as the *depth cut* and *stepover* settings increase, namely 17.65% for the outer pocket and 18.61% for the inner pocket. The surface roughness value of the ordering results ranges from 2.4-4.8 μm .

Keywords: *pocket milling, area roughing, depth cut, step over percent*

1. INTRODUCTION

CNC milling machines are machines used to make shaped materials with an automatic processing system. CNC milling is operated using a numerical control system that contains letter and number codes. Apart from being able to use programs created manually, CNC milling can also work using programs created via computer software [1].

Currently, the trend in Computer Aided Manufacturing (CAM) system development is to create CAM systems. The CAM system can recognize the special characteristics that make up a 3D model and then according to geometric shape recognition produces machining procedures and parameters [2][3].

Mastercam is software with editing and transformation capabilities that can combine 2D and 3D geometry. In Mastercam, there is a pocket processing process, namely processing a pocket pattern on a component [4]. Mastercam is software used to simulate examples of machining processes on CNC milling machines [5].

Mastercam milling toolpaths have various processing methods, namely face, contour, pocket, drill, and engrave. Facing is the process of removing the entire top surface of the workpiece. Contouring is the process of making cuts on the sides of the workpiece, both inside and outside, according to the profile created. Pocketing is the process of removing all the inside parts of the workpiece in a closed profile. Drill is a drilling process by reading selected points on the image which is carried out according to a predetermined depth. Engraving is the process of making carvings in the form of profiles or letters [6].

Daniyan [7] has researched an effective milling process with tool diameter parameters of 12, 16, and 20 mm. The results show that the material removal rate increases by an average of 40.50% for cutting operations under dissolved oil cooling conditions, with a decrease in the average temperature of 20.53% and the average surface roughness of 25.33%.

Chunhui Ji [8] has conducted experiments on the distribution of residual stress at the feed corner for 2219 aluminum alloy material. The recommended results are to increase cutting parameters such as feed rate, and radial depth of cut to achieve good compressive stress and surface roughness.

H. Abdullah, et al. [9], have researched reducing time, with a focus on parallel contour machining, to increase efficiency and performance during the process. One method is to define a tool distance greater than the cutting tool radius in roughing operations because it reduces the tool path length and machining time. Then, to validate the optimization results, cutting experiments were carried out using a CNC milling machine. From this research, it can be confirmed that clear tool path optimization provides optimal tool path length while reducing cutting time in the roughing process.

H. Abdullah, et al. [10], selecting optimal machining parameters is very important to improve machining process performance. These parameters will determine the quality of the surface finish, tool wear rate, material removal rate, and production cycle time. This research focuses on obtaining optimal machining parameters by minimizing machining time in pocket milling operations. Parameters such as feed per tooth, cutting speed, and depth of cut are considered important variables to minimize machining time in the milling process because they have significant consequences for the machining process. Based on a comparison between the genetic algorithm and Mastercam methods, the machining difference is 3.48%. This shows that genetic algorithm-based optimization can reduce production time in the machining process.

A. M. Shafie, and H. Abdullah [11], this program allows the tool path to be simulated, and the results are obtained in machining time. To achieve the optimal machining time to be used in the actual machining process, parameters such as tool diameter, federation, spindle speed, and depth of cut are evaluated. Tests show that in terms of the shortest machining time, there are three styles of machining strategies, namely high speed, parallel spiral, and Zig-Zag, which are more profitable than other commodity machining strategies. Based on this research, the tool diameter will achieve the shortest simulation time using the maximum tool diameter. Referring to the results of this research, three results are proven to produce the shortest time, namely Zig-Zag, High-Speed, or Parallel Spiral where the Zig-Zag time is 10 hours 20 minutes and the other two results are the times closest to Zig-Zag.

Petr Vavruska, et al. [12], this article focuses on the problem of controlling cutting conditions in point milling strategies to reduce machining time. Using a cutting tool with a circular cutting edge during a point milling strategy on complex shaped parts, the actual contact point between the tool and the workpiece is constantly changing. Based on this fact the cutting speed also changes continuously and the required cutting speed is not reached along the tool path. Therefore, solutions to control the spindle speed have been developed to achieve a constant value of cutting speed and consequently provide a solution to control the feed rate to maintain a constant value of feed per tooth. The applicability of this optimization technique has been proven through actual machining tests. Improved machining surface quality and machining time savings have been proven.

Habiby NA, et.al. [13] have examined the milling feed process using one-way and zig-zag methods, concluding that spindle speed and milling step method influence surface roughness.

B.S Wijanarka et al, [14] examined the time required for the pocket milling process with several different strategies as well as an analysis of tool usage. The research results stated that the fastest time for the pocket milling process was with a zigzag feeding strategy of 41 minutes 46.68 seconds.

Venkatesh [15] has researched Pocket milling using SS 304 material, different tool parameters, and zig-zag and parallel tool paths. The desired results are surface roughness and Material Removal Rate (MRR). The most optimal parameters are obtained with a spindle speed of 500 rpm, a feed rate of 30 mm/rev., and a cut depth of 0.2 mm for zig-zag

and parallel patterns. However, this research has not examined the use of inner and outer pockets, as well as variations in stepover percent.

The research is an experiment in using the Roughing Mill Area to be applied to the inner pocket and outer pocket processes. The tool used is a flat endmill with a diameter of 12 mm. Data analysis in the form of machining time, feed patterns, and surface roughness. The research is expected to obtain optimal pocket milling parameters based on the results of surface roughness and milling process time.

2. METHOD

The material used in this research is cast aluminum with dimensions of 100x100x40 mm. The equipment used includes; a CNC milling machine, HSS Ø12 end mill, and CAM software. The CAM design is in the form of inner and outer pocket milling, with the variable depth cut (depth of ingestion) used 0.5, 1, 1.5, and 2 mm, as well as a stepover percent of 40%, 50%, and 60%. Figure 1 shows the stages of research implementation. The research began with the preparation of materials in the form of cast aluminum with a length of 100, a width of 100, and a thickness of 40 mm. The 3D solid design for the inner pocket and outer pocket process is presented in Figure 1.

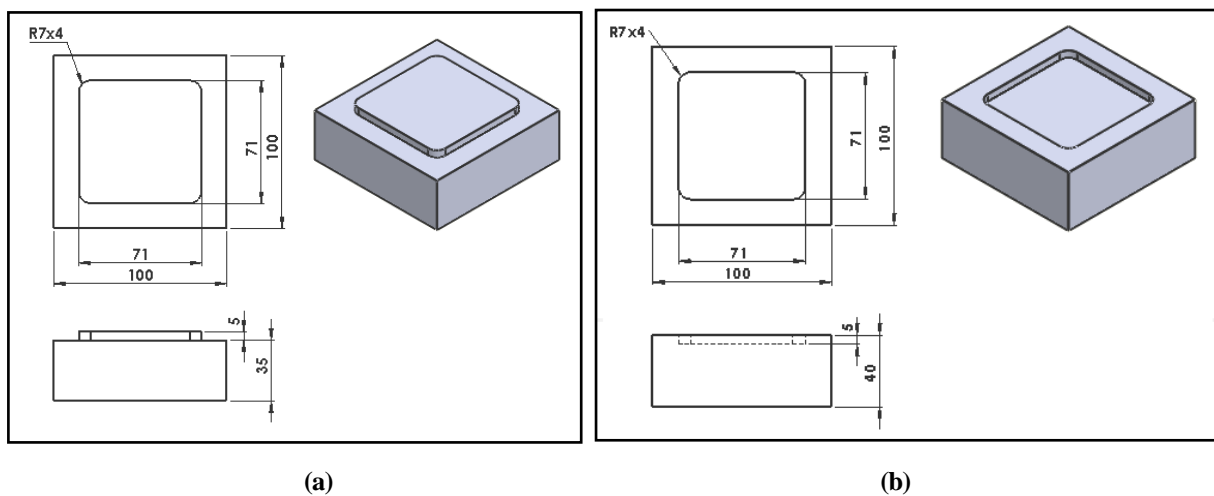

Figure 1. 3D design pocket model (a) The Outer Pocket and (b) The Inner Pocket

The next step is to set the machining parameters used, namely spindle rotation speed, feed rate, and plunge rate. The spindle rotation speed used is 1500 RPM, the feed speed is 500 mm/minute, and the plunge rate is 25.0 mm/minute. Ingestion parameters include Depth of cut using variables of 0.5, 1, 1.5, and 2 mm, while stepover percent uses variations of 40, 50, and 60%. The simulation results are in the form of NC code which is transferred to the CNC machine. Surface roughness testing using a surface roughness tester on CNC machining results.

3. RESULTS AND DISCUSSIONS

The research results are shown in Table 1 (a) & (b).

Table 1 (a). Machining Time Data

No.	Depth of cut (mm)	Stepover (%)	Feed length (mm)	Feed time (second)	Machining time (second)
1	0.5	40	11272.477	1399	1478
	1		5646.234	724	772
	1.5		3393.757	449	485
	2		2266.508	309	339
2	0.5	50	7705.731	971	1243
	1		3862.861	510	654
	1.5		2323.735	320	394

Table 1 (b). Machining Time Data, continued

No.	Depth of cut (mm)	Stepover (%)	Feed length (mm)	Feed time (second)	Machining time (second)
3	0.5	60	7645.344	964	1043
	1		3832.668	506	554
	1.5		2395.620	318	354
	2		1541.083	222	252

Table 1 (a) & (b) show the machining time, feed time in the simulation, and feed path length in the simulation. In general, it can be seen that the greater the stepover percent, the lower the machining process and simulation time. This is also the same as the feed length which will decrease as the stepover percent value increases.

While, Figure 2. shows the same cycle, where the initial feed only cuts at the corner of the workpiece. The yellow line shows movement without feeding, while the blue line shows movement with feeding.

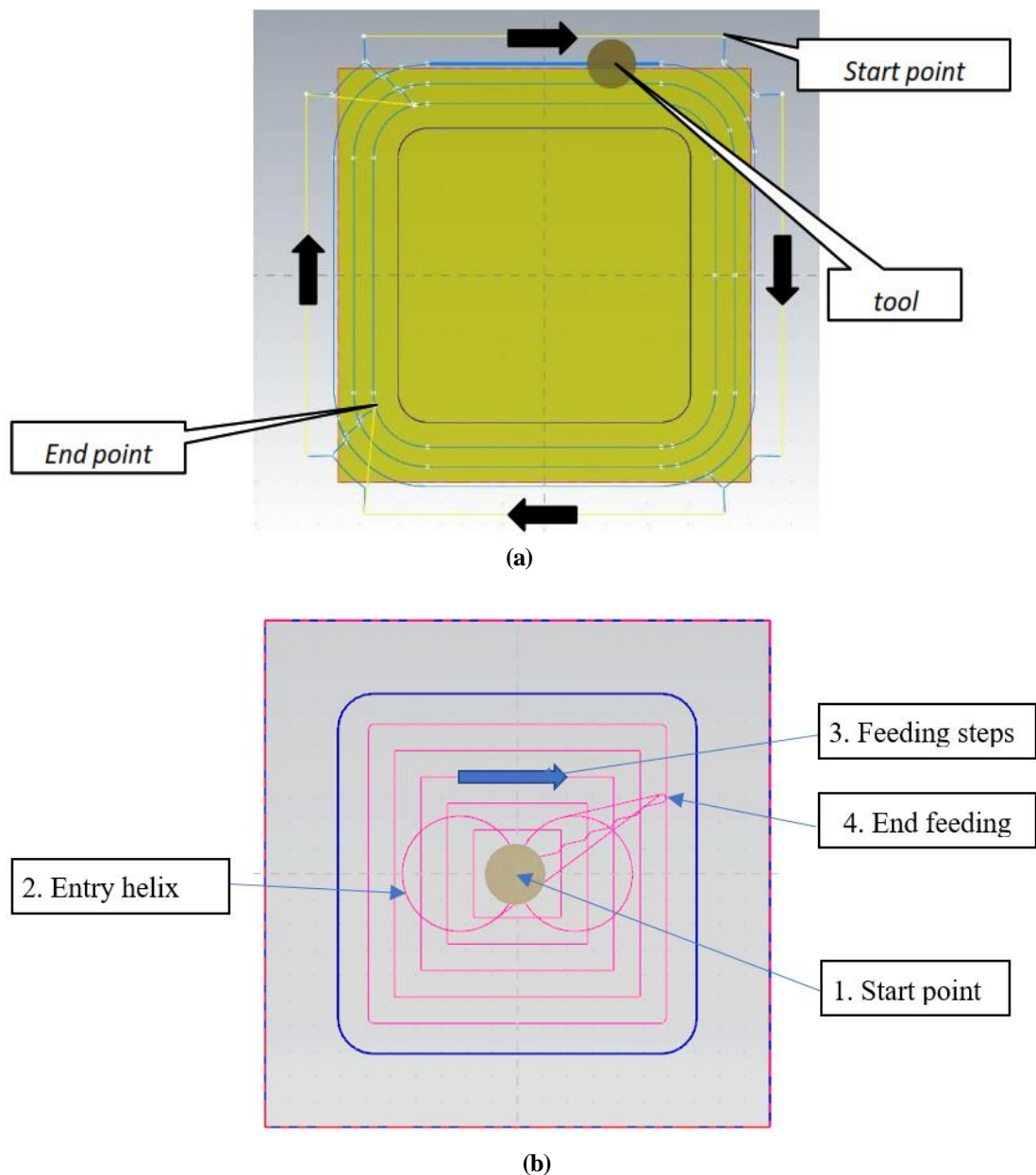

Figure 2. Top view of the 3D pocket trajectory (a) The Outer Trajectory and (b) The Inner Trajectory

Figure 3 shows the results of CNC machining, it shows the tool path with a constant distance, where the feed cycle is 4 times.

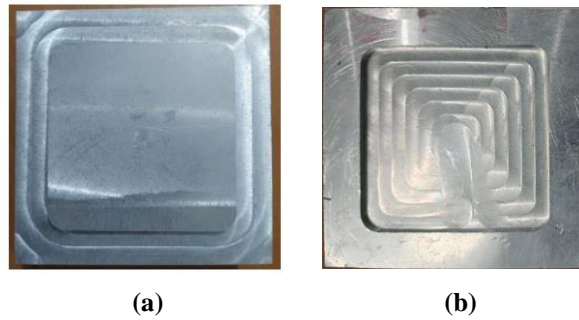

Figure 3. Machining results (a) Outer Pocket Results and (b) Inner Pocket Results

Pocket milling is a process that is widely used in making products using CNC. Optimization is often carried out by adjusting the parameters of feed per tooth, cutting speed, and depth of cut which are considered important variables to minimize machining time [10]. Figure 4 shows a graph between the machine processing time and the simulation of the depth of cut value. In general, machining time decreases as the depth of cut value increases.

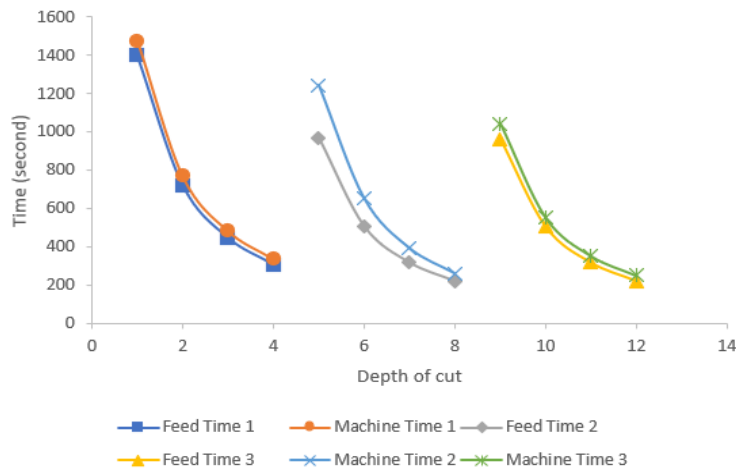

Figure 4. Comparison graph between machining time and depth of cut

The largest machining time occurs at a depth of cut value of 0.5 mm and a stepover percent of 40% with a machining time of 1478 seconds. The fastest milling process time occurs at a depth of cut of 2 mm and a stepover of 60% of 252 seconds.

Figure 5 shows the surface roughness value relative to stepover percent in each milling process. The roughness value is expressed in Roughness Average (Ra). Ra is defined as the arithmetic mean and absolute deviation of the roughness profile from the mean centerline.

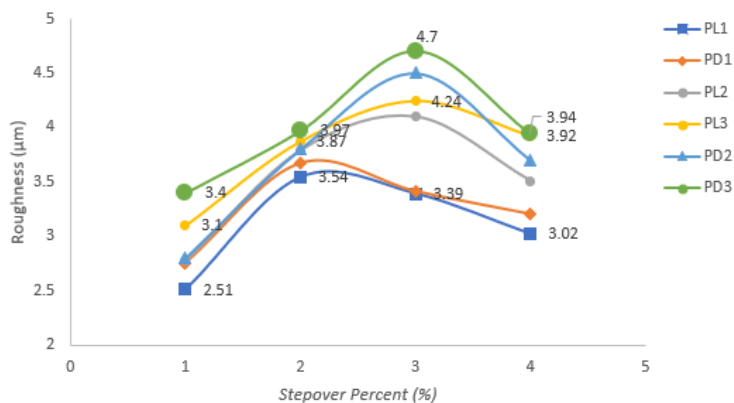

Figure 5. Comparison graph between stepover percent and surface roughness

In general, the surface roughness value increases with increasing stepover percent value. The lowest surface roughness value occurs at a stepover percent of 40% in the outer pocket 1 (PL1) process of 2.51 μm . The highest surface roughness value occurs at a stepover percent of 60% in the deep pocket 3 (PD3) process of 4.7 μm .

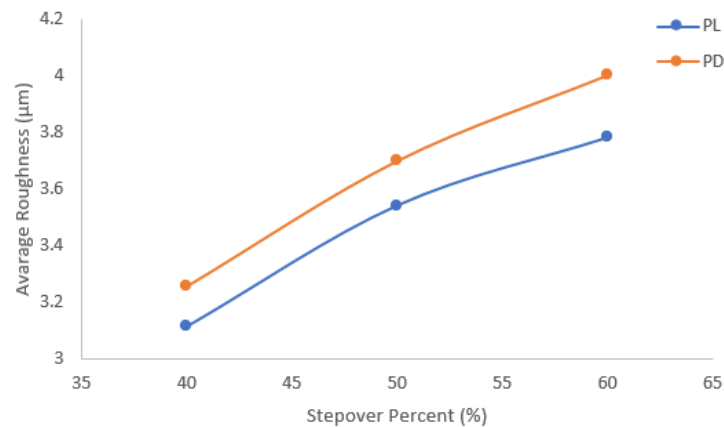

Figure 6. Comparison graph between stepover percent and average surface roughness

Figure 6 shows the average value of surface roughness relative to the stepover percent. It can be seen that in general surface roughness increases as the stepover percentage increases. This happens because the wider the distance between feeds, the phenomenon of the edge of the tool not being optimally fed so re-cleaning is required [9].

4. CONCLUSION

The pocket milling process with a roughing area can be applied to work on inner pockets and outer pockets, where what needs to be adjusted is mainly the lead in strategy parameters, where for the inner pocket a helical model movement strategy is used, while for the outer pocket, a lead in tangent strategy is used. The machining results show that the faster machining time results from larger settings for depth cut and stepover percent. Average machining time increase of 28%. Meanwhile, the surface roughness value will increase as the depth cut and stepover settings increase, namely 17.65% for the outer pocket and 18.61% for the inner pocket. The surface roughness value of the order results ranges from 2.4-4.8 μm , this surface roughness value is included in the N8 surface roughness standard, which is following the milling process standard [16].

ACKNOWLEDGMENT

The author would like to express his thanks to the Surakarta Citizens College of Technology through the Center for Research and Community Service (PPPM) which has supported, facilitated, and funded this research program, as well as the research team.

REFERENCES

- [1] Yudhyadi, JI G.N.K., Rachmanto, T., dan Ramadan, A.D. Optimasi Parameter Permesinan Terhadap Waktu Proses Pada Pemrograman CNC Milling Dengan Berbasis CAD/CAM. *Dinamika Teknik Mesin*, vol. 6, 2016, hlm.38-50.
- [2] Kariuki, L. W. (2017). Optimization of pocket milling tool path for chatter avoidance and reduced machining time (Doctoral dissertation, j).
- [3] Kariuki, L. W., Iku, B. W., & Nyakoe, G. N. (2022, March). Generation and optimization of pocket milling tool paths-A review. In *Proceedings of the Sustainable Research and Innovation Conference* (pp. 129-133).
- [4] Fahlevi, M.R., Syafri., Susilawati, A. Perencanaan CAD CAM Mesin CNC Milling Router.3 Axis Dengan Perangkat Lunak Mastercam. Jurusan Teknik Mesin, Universitas Riau, Kampus Bina Widya Panam, Pekanbaru, 2017.

- [5] Ali, A.K., Majeed, N., Hasan, N.K. 4 Comparitive Study of CNC Milling Cutting Path Strategies, *Al Nahrain Journal for Engineering Sciences (NJES)*, vol. 20, 2017, him. 214-221.
- [6] Heidari, Farzin. "Implementation of CAD/CAM/CNC curriculum using mastercam X software in technical programs." In 2008 Annual Conference & Exposition, pp. 13-702. 2008.
- [7] Daniyan, I., Mpofu, K., Fameso, F. *et al.* Computer-aided modelling and experimental evaluation of the pocket milling operation for alloy tool steel (AISI D3). *Int J Adv Manuf Technol* **122**, 4453–4466 (2022). <https://doi.org/10.1007/s00170-022-09979-3>
- [8] Ji, C., Sun, S., Lin, B., & Fei, J. (2018). Effect of cutting parameters on the residual stress distribution generated by pocket milling of 2219 aluminum alloy. *Advances in Mechanical Engineering*, *10*(12), 1687814018813055.
- [9] Abdullah, Haslina; RAMLI, Rizauddin; WAHAB, D. A. Tool path length optimisation of contour parallel milling based on modified ant colony optimisation. *The International Journal of Advanced Manufacturing Technology*, 2017, 92: 1263-1276.
- [10] Abdullah, Haslina, Nurshafinaz Isa, and Mohamad Shukri Zakaria. "Optimization machining parameters in pocket milling using genetic algorithm and mastercam." In *AIP Conference Proceedings*, vol. 2955, no. 1. AIP Publishing, 2023.
- [11] Abdullah, Haslina, and A. M. Shafie. "Simulation of Tool Path Using Conventional Method for Milling Application." *Research Progress in Mechanical and Manufacturing Engineering* 1, no. 1 (2020): 132-138.
- [12] Vavruska, Petr, Pavel Zeman, and Michal Stejskal. "Reducing machining time by pre-process control of spindle speed and feed-rate in milling strategies." *Procedia CIRP* 77 (2018): 578-581.
- [13] Habiby, M. N. A., Istianto, P. V., & Fahmi, M. (2023). Optimization Of Cutting Direction Parameters For A Cnc Milling Machining Process Pocket On Structure And Surface Roughness On Postep Motorcycle Spare Parts. *International Journal of Mechanical Engineering Technologies and Applications*, *4*(2), 135-143.
- [14] Wijanarka, B. S., S. Sutopo, W. Widarto, N. Nuchron, T. P. W. Sitorus, and A. Y. Pranyoto. "Optimization of pocket cycle machining process in computer numerically controlled milling machining." In *Journal of Physics: Conference Series*, vol. 1700, no. 1, p. 012021. IOP Publishing, 2020.
- [15] Venkatesh, R., Vijayan, V., Parthiban, A., Sathish, T., & Siva Chandran, S. (2018). Comparison of different tool path in pocket milling. *International Journal of Mechanical Engineering and Technology*, *9*(12), 922-927.
- [16] Standar DIN 4768 : 1981