

CLAMPING DIES DESIGN TO MINIMIZE AUTOMOTIVE COMPONENT DIES SETUP TIME AT PT GANDING TOOLSINDO

Sanurya Putri Purbaningrum

Program Studi Teknologi Rekayasa Otomotif
Politeknik STMI Jakarta
Email: sanuryaputri@stmi.ac.id

Indah Kurnia Mahasih Lianny

Program Studi Teknologi Rekayasa Otomotif
Politeknik STMI Jakarta
Email: indah-kml@stmi.ac.id

Edwin Sahrial Solih

Program Studi Teknologi Rekayasa Otomotif
Politeknik STMI Jakarta
Email: edwin.solih@stmi.ac.id

Abdul Wahid Arohman

Program Studi Teknologi Rekayasa Otomotif
Politeknik STMI Jakarta
Email: abdular@stmi.ac.id

Bayu Satiman

Program Studi Teknologi Rekayasa Otomotif
Politeknik STMI Jakarta
Email: bqyusqputra20@gmail.com

ABSTRAK

PT Ganding Toolsindo dihadapkan dengan permasalahan tingginya waktu *setup dies* komponen otomotif. Penyebab utama tingginya waktu setup adalah proses mengencangkan dan melepaskan baut yang dilakukan secara manual. Tujuan dari penelitian ini yaitu merancang sebuah alat bantu clamping dies yang berfungsi untuk membantu mempercepat proses pemasangan baut, sehingga waktu *setup dies* komponen otomotif berkurang. Metode yang dilakukan dalam penelitian ini adalah observasi lapangan dilanjutkan dengan proses perancangan *dies clamping*. Perancangan desain dimulai dengan menggambar objek menggunakan software CAD berdasarkan pada hasil perhitungan beban, penentuan dimensi dari dies dan mesin press serta pemilihan material dies. Selanjutnya dilakukan pembuktian bahwa rancangan *dies clamping* ini dapat mengurangi waktu *setup dies* menggunakan analisis gerakan dengan pre-determined time study metode Measurement Time Method (MTM), dimana hasilnya menunjukkan terjadi penghematan waktu sebesar 92,4%.

Kata Kunci : *dies clamping*, desain, MTM, *setup dies*

ABSTRACT

PT Ganding Toolsindo was faced with the problem of high automotive component die setup times. The main cause of the high setup time is the process of tightening and releasing the bolts which is done manually. The aim of this research is to design a tool for clamping dies which functions to help speed up the bolt installation process, so that the setup time for automotive component dies is reduced. The method used in this research is field observation followed by the die clamping design process. Design planning begins by drawing the object using CAD software based on the results of load calculations and determining the dimensions of the dies themselves and the press machine as well as selecting the dies material. Furthermore, proof was carried out that this die clamping design could reduce dies setup time using movement analysis with a pre-determined time study Measurement Time Method (MTM) method, where the results showed a time saving of 92.4%.

Keywords : *dies clamping dies*, design, MTM, *setup dies*

1. INTRODUCTION

PT Ganding Toolsindo is engaged in manufacturing automotive components and was founded in 1998 by Ir. H. Wan Fauzi. The problem faced by PT Ganding Toolsindo is the high setup time for automotive components on the machine. This causes a long process of removing and tightening bolts which is done manually [1]. The process of tightening and removing

bolts on automotive components requires work aids to streamline the process time. The use of die clamping tools aims to minimize mold assembly time which previously used a hammer. The process of making plans starts from making component drawings and dimensions using Computer Aided Design (CAD) software, followed by software design analysis based on Computer Aided Engineering (CAE). The stress on the mold clamp plate is 2.3 N/mm^2 while the manual calculation is 61.5 N/mm^2 [2]. The auxiliary clamp tool can also be used as a flaw detection tool during machining with a design according to the guidelines used. From the design made, it can be seen that the characteristics of the clamp required by the customer include: preventing vibration during machining, allowing the tool to reach the entire surface of the workpiece, positioning the workpiece well before and during the process, preventing freezing, quick and easy setup.

Ahmadi, R and Poernomo, H designed tools to make it easier to open and close the mold. The problem being faced by PT Berliana is that there are no tools to open and close the mold so that the process of opening and closing the mold has been using a very large copper hammer. The purpose of using this tool is to minimize mold assembly time which previously used a hammer. The design process starts from making component drawings and dimensions using Computer Aided Design (CAD) software, followed by analysis of the design software based on Computer Aided Engineering (CAE). The stress on the mold clamp plate is 2.3 N/mm^2 while the manual calculation is 61.5 N/mm^2 [2]. Costa, C et al conducted research to overcome the problem of gripping materials with complex shapes with manual control so that it is difficult to detect if dimensional errors occur. Research was carried out by developing a clamping tool with hydraulic power or what could be called a hydraulic clamp. Hydraulic Clamping is designed according to the part to be clamped, making it easier to use. The clamp characteristics required by customers include: preventing vibration during machining, allowing the tool to reach the entire surface of the workpiece, positioning the workpiece well before and during the process, preventing deformation, quick and easy adjustment. The clamp consists of a hydraulic circuit and a supporting structure. The results show that clamp tools can increase a company's production capacity by reducing production costs, reducing lead time and reducing the occurrence of product defects [3].

Making a clamp/vise to clamp the workpiece on a milling machine begins with designing 2D and 3D drawings of the hydraulic vise, followed by calculating the working forces and then carrying out design analysis using Finite Element Analysis (FEA) based software. The results show that the designed hydraulic vise has a permissible stress of 125 N , a compressive force of 39.2 N , a cutting force of 74.4 N , a shear force of 74.46 , a friction force of 29.008 , a maximum bending stress of $14.06 \times 106 \text{ MPa}$, a maximum shear stress of 39 MPa , a twisting moment of 11.34 Nm , Circumferential force 2.268 N , maximum grip force 38.92 N [4]. The hydraulic construction of the clamping unit is used to design a hydraulic system for the mold clamp unit which functions to press and hold the mold platen. The aim of holding the mold is so that during the material injection process into the mold there is no movement or opening. The force that must be withstood by the clamping unit system is more than 700 tons [5].

The cylinder design of the hydraulic cylinder used in gripping workpieces from CNC machine tools is specifically for guide disks. Numerical control methods are used for clamping automation, spindle control, telescopic hydraulic control, and holistic structural design. Active isolation technology is used to increase reliability and stability. The results show that an automatic clamping design has been obtained where as long as the button is pressed by the operator, the workpiece will be clamped quickly by itself. In addition, it has also been proven to be stable, safe, reducing operator labor intensity [6].

The role of the hydraulic system to support clamping is carried out with a total load of 500 kg using a piston with a pressure of 70.77 kg/cm^2 with a cross-sectional area of $7,065 \text{ cm}^2$ [7]. Designing a hydraulic press machine with a capacity of 50 tons requires a fluid pressure (P) of 250 bar with a maximum force loading of 490.5 N and a maximum tensile stress of 1172 N/mm^2 [8]. It is necessary to pay attention to the selection of hydraulic press machine materials in order to produce a design that is safe and in accordance with the desired criteria [9]. Simulation and design modeling is one method that can be used to improve the performance of hydraulic press machines [10]. The control system can be one of the additional devices implemented on a hydraulic press machine to detect leaks in the piston [11]. The performance results from the simulation are then compared to determine the effectiveness of the design [12]. Another factor that must be considered in designing a hydraulic machine is work safety [13]. The tools designed must be ensured to be safe to operate and not have an impact on user safety. The role of a hydraulic tool must also pay attention to the cost factor required [14]. The more sophisticated the technology used, the more costs will be incurred.

The Single Minute Exchange of Dies (SMED) method is often used to reduce dies setup time in various companies, one of which is PT Ganding Toolsindo. The equipment used is a hydraulic table which can help move the dies from the die storage area to the press machine. The results show that using a hydraulic table as a tool for dies moving can increase the dies moving rate by 46% [15]. In this research, a design tool will be created which aims to speed up the die setup process. The total die setup time is 35.73 minutes per setup. Meanwhile, the time used to remove the bolt was 107 seconds [1]. The work aid design made in this research is in the form of clamping dies which are expected to reduce machine setup time. The use of die clamping tools can eliminate the operator's work in removing and tightening bolts during the press machine die setup process at PT Ganding Toolsindo.

2. METHOD

The research stage begins with looking for references either through literature or direct observation in the field. During field observations, observations were made regarding die replacement activities at PT Ganding Toolsindo. The next stage is to formulate the problem to be raised in the research followed by determining the research objectives.

The data collection stage begins by collecting data on the dimensions of the brand C press machines. Data collection on press machine dimensions is carried out by taking direct measurements of the press machine used. The next data is the weight of the dies used. All dies used in the press machine are recorded so that the largest die weight is obtained. The last data needed is the dies material data used. Die material data was carried out by conducting interviews with the factory owner PT Ganding Toolsindo. From the data obtained, the mechanical properties are then searched from the references that have been studied.

After getting the initial data, namely machine dimensions, dies weight and dies material, the next step is to create a Clamping Dies design drawing. The design drawing I made includes the upper clamp and lower clamp designs along with detailed sizes.

The final step after making the design drawing is to analyze the bolt installation movement so that the length of time for installing the dies can be known so that the savings that occur by using dies clamping tools can be determined.

2.1. Dimension

Brand C press machines dimensional data is carried out by taking direct measurements on the press machine. Next, from this data, a drawing of the press machine and its dimensions is created using CAD software. These can be seen in Figures 1 and 2.

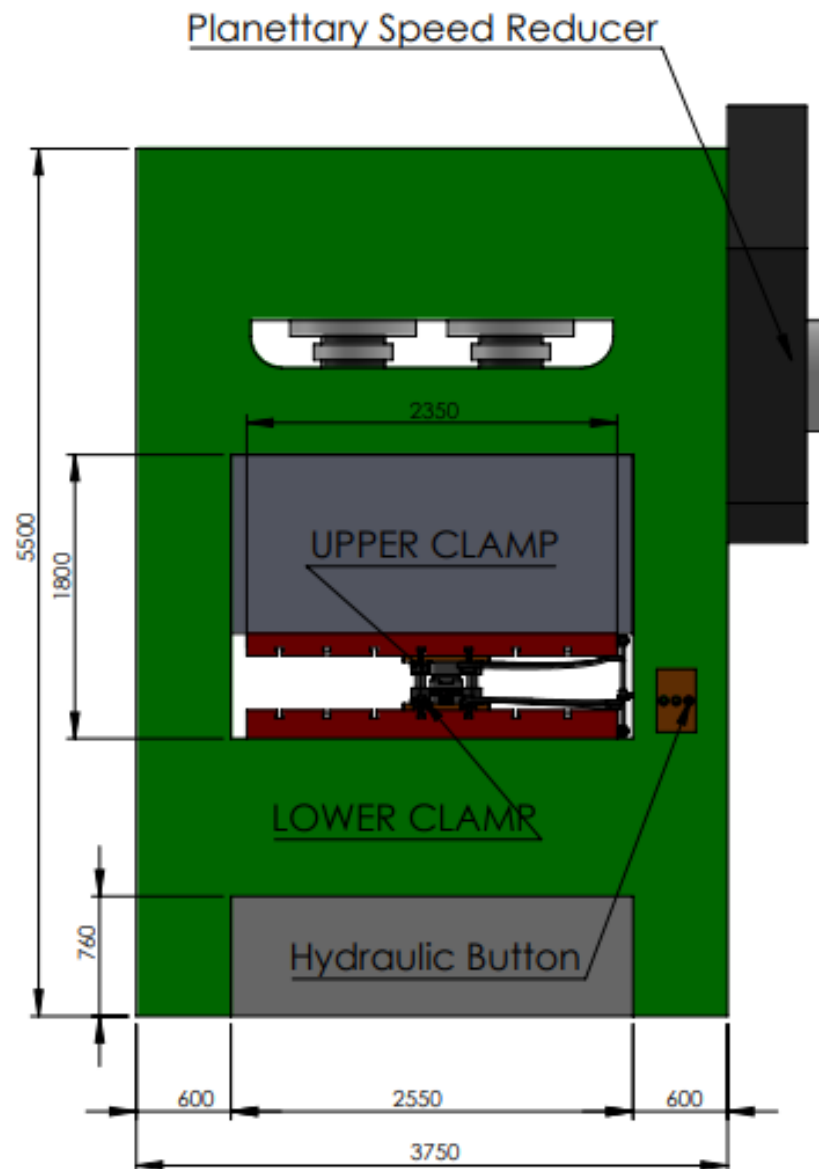

Figure 1. Front view of the press machine

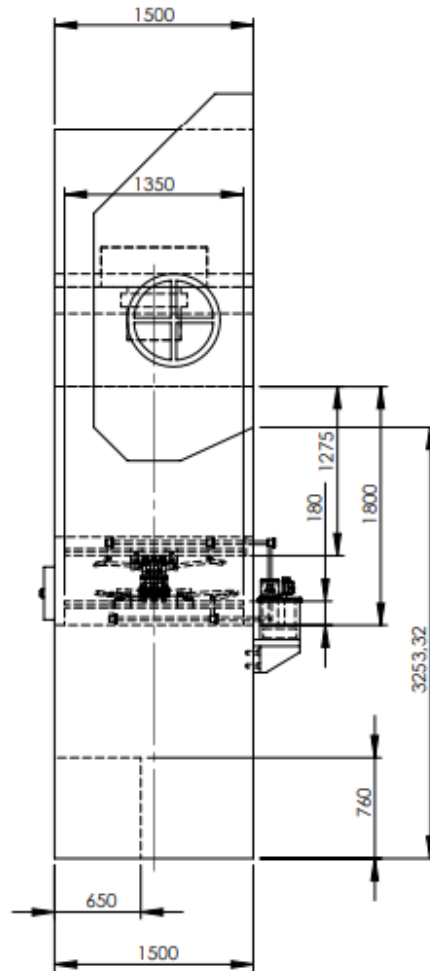

Figure 2. Side view of the press machine

From those Figures we can see that the total length of the press machine is 3750 mm, the width of the press machine is 1500 mm, and the total height of the press machine is 5500 mm. Meanwhile, the machine table has a length of 2350 mm, a width of 1350 mm and a maximum height of 1800 mm. The clamping dies will be placed in which Tslot on the machine table which functions to clamp the dies automatically as depicted in Figure 3.

In Figure 3 we can see the complete dimensions of the Tslot die machine table. This size will later be adjusted to the size of the clamping dies so that they can fit into the Tslot.

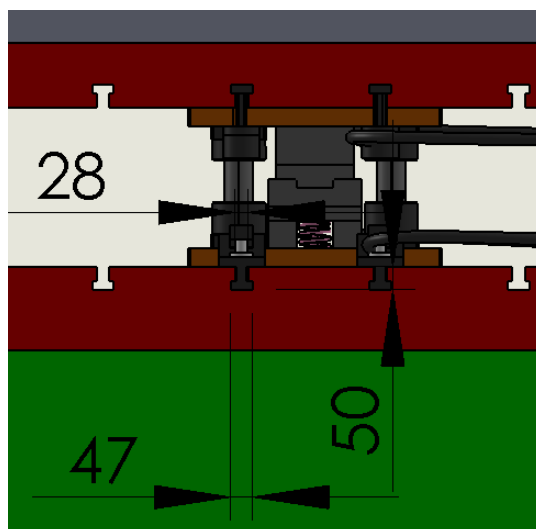

Figure 3. Dimension of Tslot

2.2. Weight of the dies

The weight of the dies is done by taking weight data on each dies used at PT Ganding Toolsindo. The dies data used can be seen in Table 1.

Table 1. Dies used on brand C press machines

No.	Name Dies	Part	Process	Dimension (l x w x h)	Weight (kg)
1	Dies 1	65258/68	Blank	900 x 700 x 460	1200
2	Dies 2	Basepan	Blank	900 x 580 x 420	900
3	Dies 3	Nut Raw	Blank/Pie	950 x 530 x 470	1857
4	Dies 4	Washer 1	Blank/Pie	1000 x 450 x 460	800

From the data in Table 1, the largest die size is taken, namely 1875 kg, in the calculations it is rounded up to 2000 kg.

2.3. Material dies

The material used in making dies is SS-41 material or often called assental iron. Assental iron, is a type of iron that is processed through forging and pressing at high temperatures. This process produces a material with superior mechanical properties, including high tensile strength and exceptional resistance to corrosion. Meanwhile, the material used to make the clamping dies is SS-45.

3. RESULT AND DISCUSION

Initial data is obtained from the dimensions of the press machine and the dimensions of the Tslot used. The Tslot dimensions are 47 mm long at the bottom, 4 mm high and 28 mm wide at the top. From this data, the dimensions of the clamp that will be designed can be calculated. The dies used weigh 2000 kg. The number of clamps that will be designed is 4, with details of 2 upper clamps and 2 lower clamps. The two Upper Clamps are installed diagonally as are the 2 lower clamps which are installed diagonally. The distribution of load on each clamp can be seen in the Equation 1:

$$F = \frac{2000 \text{ kg}}{4} = 500 \text{ k} \quad (1)$$

where

F = load on each clamp

3.1. Upper Clamp Design

From the results of temporary data processing, the dimensions of the Upper Clamp are obtained along with a design drawing of the upper clamp that will be used. The Upper Clamp design drawing can be seen at Figure 4.

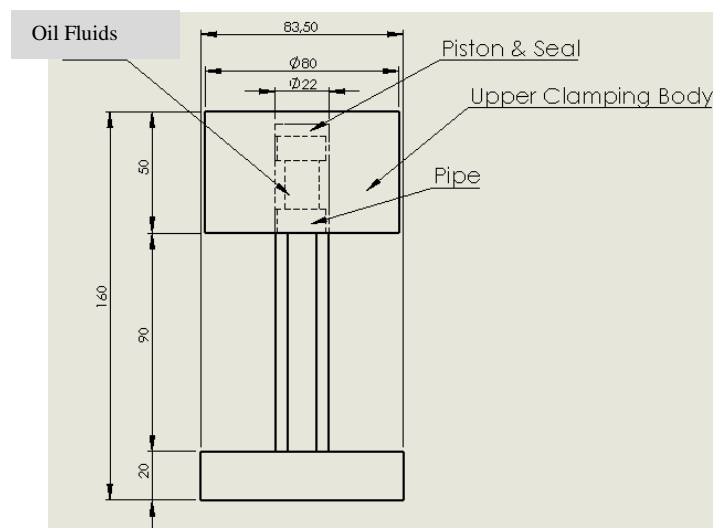

Figure 4. Upper clamp design

Notes:

- $D_{rod} = 22 \text{ mm}$
- $D_{cyl} = 30 \text{ mm}$
- $Disp = 20 \text{ mm}$
- $D_{body} = 80 \text{ mm}$

The upper clamp movement mechanism is that when the clamp clamps, the piston will move down so that fluid enters the cylinder which makes the cylinder move down and clamps the die. On the other hand, when the clamp is opened, the piston will move up so that fluid comes out of the cylinder, causing the cylinder to rise.

3.2. Lower Clamp Design

The design and dimensions of the lower clamp can be seen at Figure 5 and Figure 6.

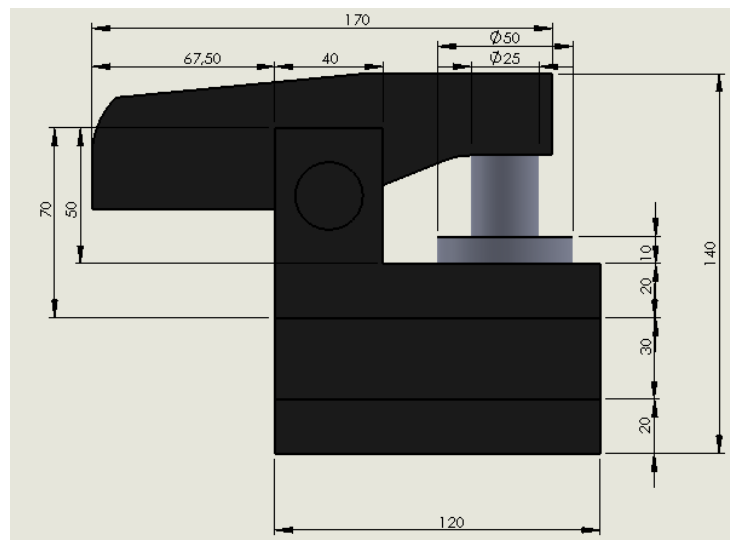

Figure 5. Lower clamp design front view

From Figure 5, the front view of the lower clamp can be seen that the upper dimensions are 170 mm long and the lower dimensions are 120 mm long. The height of the lower clamp is 140 mm. The outer diameter of the cylinder is 50 mm and the inner diameter of the cylinder is 25 mm.

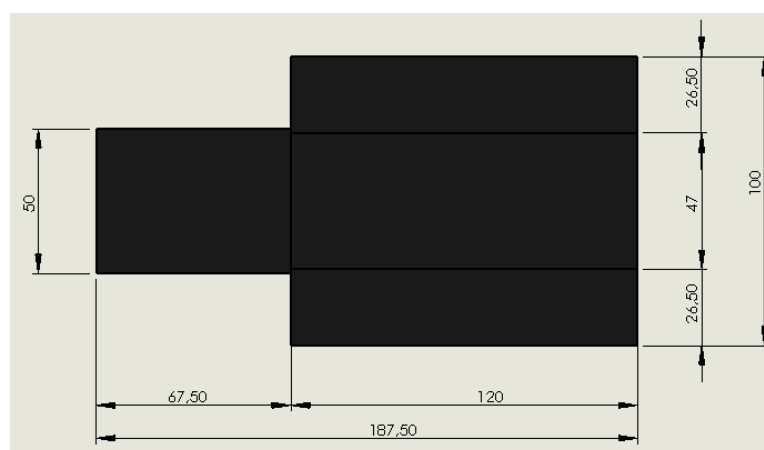

Figure 6. Lower clamp design bottom view

Figure 6 shows the lower clamp design. From this picture, you can see the width dimensions of the lower clamp. The width of the lower clamp on the left (clamp) is 50 mm, while the width on the right (where the piston) is 100 mm.

The movement mechanism is that when the clamp clamps, the piston will move forward and the fluid will move in, making the left clamp lever move down so that it clamps the bottom die. Conversely, when the clamp is

opened, the piston will move backwards so that the fluid in the chamber comes out, causing the clamp lever to rise.

3.3. Analysis of the Movement of Removing Bolts and Tightening Bolts in the Dies Setup Process

The use of clamping dies will affect the setup dies process. The process of removing bolts manually will disappear when you use this die clamping tool. The initial process was to open the bolts one by one manually using a ring wrench, replaced by using a clamping die where the tightening process is automatically assisted by hydraulic power. The process of removing the clamping dies on the front and back of the upper die is as follows:

1. The operator presses the hydraulic button for the upper clamp to the off position
2. The operator grabs the left and right front upper clamps with both hands simultaneously
3. The operator pulls and releases the left and right front clamps from the T-Slot with both hands simultaneously
4. The operator places the clamp
5. The operator releases the clamp on the back of the upper die
6. The operator grabs the left and right clamps together with both hands
7. The operator pulls and releases the left and right clamps from the T-Slot with both hands simultaneously
8. Operator places the clamp

Meanwhile, for the process of removing the clamp on the lower die, the process is as follows:

1. The operator presses the hydraulic u clamp lower system button
2. The operator reaches for the lower die clamps on the left front and rear
3. The operator pulls and releases the clamp on the lower die on the front and rear left of the T-Slot
4. Operator grabs the right front and rear clamps
5. The operator pulls and releases the rear clamp bag from the T-Slot

3.4. Analysis of the Time to Remove Bolts and Tighten Bolts in the Dies Setup Process

Based on the analysis of the movement of removing the clamp for the upper die and lower die, the time was determined using a pre-determined time study with the MTM method. Where the steps taken are to analyze the movement and determine the time to release the clamp on the upper die and lower die based on the MTM Table and mapping the movement using the Right Hand and Left Hand Map (Assuming the length of the hand reach to the die clamping tool is 30")

Based on mapping with right-hand and left-hand maps and the MTM method, the time required to remove the upper die clamp is 158.3 TMU, where 1 TMU = 0.036 seconds, so the time to remove the upper die clamp is $158.3 \text{ TMU} \times 0.036 \text{ seconds} = 5.7 \text{ seconds}$.

Based on mapping with right-hand and left-hand maps and the MTM method, the time required to remove the lower die clamp is 66.7 TMU, where 1 TMU = 0.036 seconds, then the time to remove the upper die clamp is $66.7 \text{ TMU} \times 0.036 \text{ seconds} = 2.4 \text{ seconds}$.

The total time to remove the upper die and lower die is $5.7 \text{ seconds} + 2.4 \text{ seconds} = 8.1 \text{ seconds}$. Meanwhile, if you remove the upper die with a manual bolt, it takes 107 seconds (Source: Competitive Research Report "Implementation of SMED in the SEYI SN2-300 Press Machine Die Replacement Process at PT Ganding Toolsindo), so it clearly shows that if the bolt is manual to tighten the upper die and Lower die will result in time savings of 98.9 seconds or a decrease in die removal time of 92.4%.

4. CONCLUSION

The conclusion obtained from the data processing that has been carried out is that a dies clamping design has been obtained in the form of an upper clamp and a lower clamp that can withstand a maximum die load of 5 kg with SS-45 iron material and the results of the pre-determined time study analysis with the proposed Replacing bolts using a die clamping tool can reduce setup time by 92.4%.

ACKNOWLEDGEMENT

Thank you to PT Ganding Toolsindo as a research partner and thank you to the STMI Jakarta Polytechnic for facilitating this research activity

REFERENCES

- [1] Lianny, I. K. M., Purbaningrum, S. P., & Solih, E. S. (2022). Implementation of Single Minute Exchange of Dies at PT Ganding Toolsindo. *Proceedings of the 2022 International Conference on Engineering and Information Technology for Sustainable Industry*, 1-6.

- [2] Achmadi, R., & Poernomo, H. (2020). Rancang Bangun Clamp Pembuka dan Penutup Mold dengan Hidrolik clamp. *Jurnal Techno Bahari*, 7, 17–20.
- [3] Costa, C., Silva, F. J. G., Gouveia, R. M., & Martinho, R. P. (2018). Development of hydraulic clamping tools for the machining of complex shape mechanical components. *Procedia Manufacturing*, 17, 563–570. <https://doi.org/10.1016/j.promfg.2018.10.097>
- [4] Restu, F., Hakim, R., Anwar, F. S., Huda, M. K., Lohbener, J., No, L., Lohbener, K., Indramayu, K., Harwanto, I., Sidi, Pranowo, P Sidi, B. B., Harijono, & Purwanto, H. (2018). Studi Maksimal Cekam pada Ragum Hidrolik. *Mechonversio: Mechanical Engineering Journal*, 1(2654), 130–135.
- [5] Amran, P. S. (2017). Perencanaan Konstruksi Sistem Hidrolik Pada Clamping Unit Untuk Mesin Cetakan Injeksi Plastik Kapasitas 700 ton. *Jurnal Teknik Mesin ITI*, 1(2), 59. <https://doi.org/10.31543/jtm.v1i2.31>
- [6] Yang, K., Guan, S., & Wang, C. (2011). The design & calculation for hydraulic cylinder of workpiece hydraulic clamping system of a special CNC Machine for Guide Disc. *Procedia Engineering*, 16, 418–422. <https://doi.org/10.1016/j.proeng.2011.08.1105>
- [7] Solih, E. S., Hayoto, V., & Purbaningrum, S. P. (2023). Perancangan Hydraulic System Dalam Rangka Mendukung Dies Clamping Pada Mesin Press Seyi SN2-300 di PT Ganding Toolsindo. VIII(4), 7387–7393.
- [8] Nainggolan, A. F., Herisiswanto, & Cupu, D. R. P. (2020). Perancangan komponen sistem hidrolik pada mesin press kapasitas 50 ton. *Jom FTEKNIK*, 7, 1–9.
- [9] Okolie, P. C., Obika, E. N., Oluwadare, B. S., Ezenwa, O. N., & Udensi, C. S. (2020). Steel work design and analysis of a 40-ton constant temperature hydraulic press. *Heliyon*, 6(9), e04783. <https://doi.org/10.1016/j.heliyon.2020.e04783>
- [10] Jankovič, D., Šimic, M., & Herakovič, N. (2024). A data-driven simulation and Gaussian process regression model for hydraulic press condition diagnosis. *Advanced Engineering Informatics*, 59(July 2023). <https://doi.org/10.1016/j.aei.2023.102276>
- [11] Macchelli, A., Barchi, D., Marconi, L., & Bosi, G. (2020). Robust adaptive control of a hydraulic press. *IFAC-PapersOnLine*, 53(2), 8790–8795. <https://doi.org/10.1016/j.ifacol.2020.12.1384>
- [12] Waskito, K. T., Geraldi, A., Ichi, A. C., Yanuar, Rahardjo, G. P., & Al Ghifari, I. (2024). Design of hydraulic power take-off systems unit parameters for multi-point absorbers wave energy converter. *Energy Reports*, 11(February 2023), 115–127. <https://doi.org/10.1016/j.egy.2023.11.042>
- [13] Munir, M. and A. W. (2020). Perancangan Alat Hidrolis Yang Ergonomis Guna Meningkatkan Performance Kerja Service Sepeda Motor. *Journal Mechanical and Manufacture Technology*, 1(2), 66–78. <https://jurnal.yudharta.ac.id/v2/index.php/jmmt/article/view/2317%0Ahttps://jurnal.yudharta.ac.id/v2/index.php/jmmt/article/download/2317/1688>
- [14] Sibanda, V., & Murena, E. (2023). Realisation of Design Methodologies and Tools in Modern Manufacturing Systems. *Procedia CIRP*, 119, 468–473. <https://doi.org/10.1016/j.procir.2023.03.109>
- [15] Agustin, D., Arohman, A. W., Agus, M., & Sudrajat, H. (2023). Analisis Peningkatan Waktu Setup Menggunakan Sistem Meja Hidrolik Dengan Metode Single Minute Exchange Die (SMED) Di PT Ganding Toolsindo. *Jurnal Teknologi Dan Manajemen*, 21(2), 67–74. <https://doi.org/10.52330/jtm.v21i2.107>