COMPARATIVE ANALYSIS OF PRESSURE AND FLOW CHARACTERISTICS IN BASIC AND MODIFIED AIR COMPRESSOR PIPELINE USING COMPUTATIONAL FLUID DYNAMICS IN POWER PLANT TANJUNG ENIM 3X10 MW

Gurruh Dwi Septano

Department of Mechanical Engineering
Politeknik PGRI Banten, Serang, Indonesia
Email: gurruh@politeknikpgribanten.ac.id

Tri Satya Ramadhoni

Department of Mechanical Engineering
Politeknik Negeri Sriwijaya, Palembang, Indonesia
Email: tri.satya.ramadhoni@polsri.ac.id

Herlin Sumarna

Department of Mechanical Engineering
Politeknik Negeri Sriwijaya, Palembang, Indonesia
Email: herlin.sumarna@polsri.ac.id

ABSTRAK

Kompresor udara adalah perangkat penting yang mengubah energi listrik menjadi energi kinetik sebagai udara bertekanan. Studi ini berfokus pada kinerja dua kompresor yang beroperasi bergantian, dengan satu kompresor dalam mode siaga. Namun, unit kompresor #1 menghadapi masalah dengan sistem pengeringnya, sehingga tidak dapat beroperasi dalam jaringan pipa yang ada. Untuk memungkinkan fungsinya, modifikasi pada jaringan pipa diusulkan dan dianalisis. Penelitian ini menggunakan Computational Fluid Dynamics (CFD) untuk mengevaluasi dan membandingkan karakteristik tekanan dan aliran dalam konfigurasi pipa yang ada dan yang telah dimodifikasi. Analisis CFD dilakukan dengan menggunakan perangkat lunak rekayasa dengan komputer, dengan SolidWorks sebagai alat pemodelan dan simulasi. Bilangan Reynolds yang digunakan diasumsikan dalam aliran laminar yang telah mempertimbangkan diameter pipa dan laju volume kompresor. Data CFD yang dihasilkan memberikan wawasan tentang distribusi tekanan dan kecepatan dalam jaringan pipa yang ada dan yang dimodifikasi. Pada simulasi tekanan, tekanan permukaan serta output pada pipa standar dan pipa modifikasi relatif memiliki nilai yang tekanan yang sama di 7 bar, sedangkan untuk simulasi kecepatan udara, pada permukaan pipa standar dan modifikasi masih relatif sama pada berada pada kisaran 0 – 5 mm/s, namun terdapat dari sisi output pipa, kecepatan udara pada pipa standar dan modifikasi memiliki kontur kecepatan yang berbeda, yang mana pada pipa standar kecepatan tertinggi berada di antara 0,25 – 0,38 mm/s sedangkan untuk pipa modifikasi kecepatan tertinggi berada di 0,15 – 0,2 mm/s. Dengan menyajikan evaluasi komprehensif terhadap modifikasi yang diusulkan, studi ini bertujuan untuk meningkatkan pemahaman tentang dinamika fluida yang terlibat dalam sistem kompresor udara. Hasil penelitian ini dapat berkontribusi pada optimasi kinerja dan efisiensi dari sistem-sistem tersebut, dengan demikian memberikan manfaat pada berbagai aplikasi industri.

Kata kunci: kompresor, jaringan pipa, *computational fluid dynamics*, tekanan, aliran.

ABSTRACT

Air compressors play a crucial role by converting electrical energy into kinetic energy in compressed air. This study explicitly assesses the performance of two compressors that operate alternately, with one in standby mode.. Unfortunately, compressor unit #1 faced issues with its drying system, rendering it unable to function within the current pipe network. In order to rectify this, proposed modifications to the pipeline network are introduced and scrutinized. To analyze these modifications, Computational Fluid Dynamics (CFD) is employed to evaluate and compare pressure and flow characteristics in both the existing and modified pipe configurations. The CFD analysis utilizes computer engineering software, with SolidWorks serving as the primary modeling and simulation tool. The assumption is made that the Reynolds number corresponds to laminar flow, factoring in pipe diameter and compressor volume rate. The resulting CFD data offers valuable insights into pressure and velocity distributions within the existing and modified pipeline networks. During the pressure simulation, surface pressure and output on both standard and modified pipes exhibit relatively similar pressure values at 7 bar. However, in the air velocity simulation, surfaces of standard and modified pipes maintain a consistent range of 0 – 5 mm/s. Notably, air velocity in standard and modified pipes display distinct speed contours from the pipe output side. Standard pipes show the highest speed between 0.25 and 0.38 mm/s, whereas modified pipes exhibit the highest speed within the 0.15 to 0.2 mm/s range. This study aims to provide a comprehensive evaluation of the proposed modifications, seeking to enhance understanding of the fluid dynamics within air compressor systems. The outcomes of this research have the potential to contribute significantly to optimizing the performance and efficiency of these systems, thereby offering benefits across various industrial applications.

Keywords: *compressors, pipeline, computational fluid dynamics, pressure, flow.*

1. INTRODUCTION

An air compressor is a device that converts power using a motor or engine into potential energy stored in pressurized air. Using one of several methods, an air compressor gradually forces air into a storage tank, incrementally increasing the pressure. When the tank pressure reaches its upper limit, the air compressor shuts off. The compressed air is then held in the tank until needed. The energy contained in the compressed air can be utilized for various applications, harnessing the kinetic energy as the air is released and the tank depressurizes. As the tank pressure drops to its lower limit, the air compressor turns on again to re-pressurize the tank [1]. Two compressors work in shifts with one compressor in standby mode. However, operational compressors occasionally encounter issues, leading to damage, trips, or shutdowns for safety and maintenance purposes. During these periods, compressor unit #1 experienced trouble with its dryer system. Damage to the dryer system can introduce water vapor into the compressed air, causing adverse effects on the production process [2]. To prevent such issues, modifications to the compressor's pipeline leading to the dryer are proposed. This modification would allow compressor unit #1 to operate independently of dryer unit #2. The pipeline design must consider potential pressure losses, which can vary depending on factors such as component type, pipe material, transported fluid, and pipe fittings. Analyzing the pipeline is crucial from an engineering standpoint, as many engineering problems are related to it. Due to its significant engineering applications and implications, pipe analysis is essential for measuring fluid flow [3]. To analyze the compressor's pipeline, Computational Fluid Dynamics (CFD) can be employed. CFD is defined as a branch of fluid mechanics that solves and analyzes fluid flow problems, using numerical methods and algorithms. In order to perform the calculations required to simulate the fluid surface interaction, defined by boundary conditions, computers need to be employed. High-speed supercomputers can be applied to find better and faster solutions [4]. CFD combines physics, flow technology, computer applications, mathematics, and mechanics to predict fluidic system behavior by satisfying mass, momentum, and energy conservation principles. CFD, presented in modern Computer-aided engineering (CAE) software, is a valuable tool for investigating physical system design and performance variables, as well as diagnosing or troubleshooting system behavior [3]. There are several researchers who use CFD in completing their research such as

analyzing fluid flow in the form of air for air flow patterns against the shape of a vehicle frame [5]. Conducted using Ansys application, designing pipe systems to simulate the flow of liquids and gases in pipes that allow efficient analysis of the effects of fluid flow on a pipe system [6] conducted using Solidworks application and there is also a prediction of particle erosion characteristics in turbulent gas flow at pipe elbows in the oil and gas production industry [7].

For the CFD simulation in this study, Autodesk CFD software was used to analyze the pressure and velocity of laminar air flow in two different piping systems, namely standard piping and piping that has been modified from a compressor in a power plant industry 3X10 MW in Tanjung Enim.

2. METHOD

2.1 Pipeline Configuration

Compressors are connected through a pipeline to the dryer and pass through the air tank. In the basic configuration of the pipeline, compressor unit #3 is connected to dryer unit #3. In the modified configuration of the pipeline, compressor #1 can be connected to another dryer in addition to dryer unit #2. The basic configuration and the modified configuration of the compressor's pipeline are illustrated in Figure 1 and Figure 2, respectively.

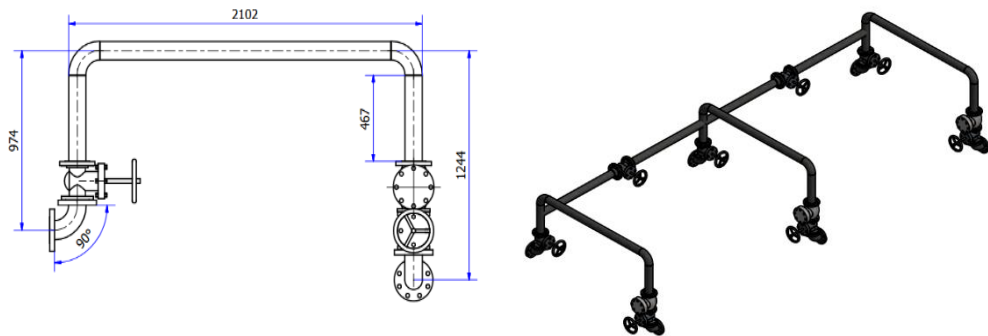

Figure 1. Basic Pipeline Compressors in Power Plant Tanjung Enim 3x10 MW

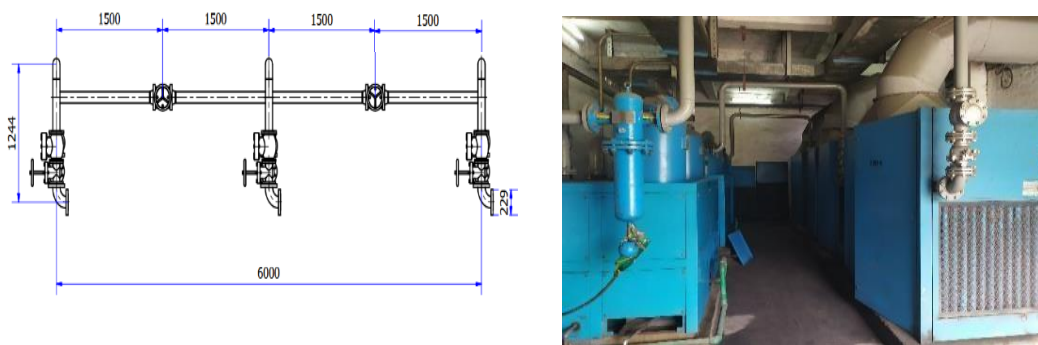

Figure 2. Plan of Modification Pipeline Compressors in Power Plant Tanjung Enim 3x10 MW

In the modified configuration, globe valves are employed to regulate the opening and closing of the inlet flow to the dryer. Globe valves are chosen for the main line pipe modification due to their seating orientation, which is parallel to the line of flow. However, the change in the fluid flow direction through these

valves results in increased resistance and significant pressure drop. Moreover, globe valves are recommended for services that require frequent operation and provide positive control [8].

The analysis will investigate the flow and pressure between compressor #1 and dryer #2 in the modified pipe and between compressor #3 and dryer #3 in the basic pipe. The analysis schematic for basic and modification pipeline is depicted in Figure 3 and Figure 4.

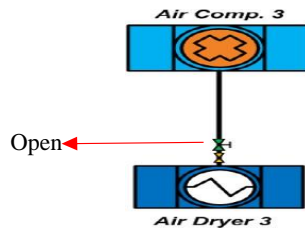

Figure 3. Basic Pipe Schematic Analysis compressor pipeline system

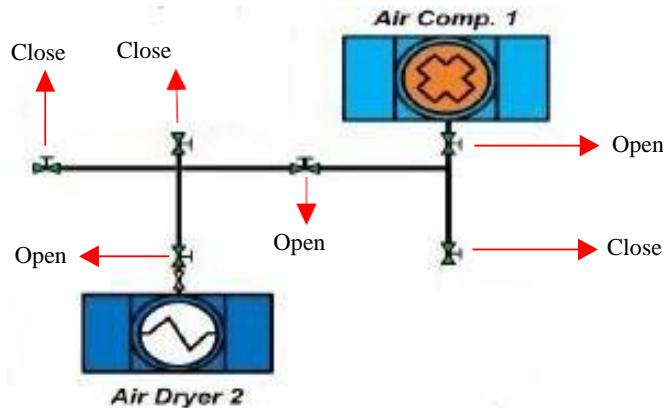

Figure 4. Modification Schematic Analysis compressor pipeline system

2.2 Governing The Equation

Reynolds numbers can distinguish between laminar and turbulent flow. Laminar flow occurs when the Reynolds number is below 2000, while turbulent flow is observed when the Reynolds number exceeds 2000. This flow classification is crucial for establishing the initial conditions for flow simulation in the pipe. According to Equation 1, the Reynolds number of the pipe is calculated to be 1696, indicating a laminar flow regime. Additionally, non-slip and impermeability boundary conditions are applied to the walls, while a prescribed outlet condition sets the minimum pressure at the channel outlet to 7 bar, consistent with the standard compressor operating on the pipe. Equation 1 provides the formula for calculating the Reynolds number.

$$Re = \frac{\rho v D}{\mu} \quad (1)$$

The density of air (ρ) is set at 1.2 kg/m^3 , while the air viscosity (μ) is taken as 0.01813×10^{-3} . The pipe diameter is 80 mm, and the velocity value (v) of 0.000318 is derived using the volume rate equation. The formula for the volume rate is presented in Equation 2.

$$v = \frac{Q}{A} \quad (2)$$

2.3 Modeling and Simulation

The pipeline configurations are modeled in Solidworks, with an outer diameter of the pipe of 88.10 mm and an inner diameter of 80 mm, both having equal lengths. The pipe material used is galvanized steel. For the basic configuration, the inlet is connected to air compressor #3, while for the modified configuration, the inlet is connected to air compressor #1. The fluid utilized in the simulation is air, with a constant density of 1.2 kg/m^3 . The boundary conditions were established for volume rate and pressure, maintaining a uniform temperature of 25°C . At the inlet, a constant volume rate of $16 \text{ m}^3/\text{min}$ was applied, while at the outlet section, the pressure was set to 7 bars. The walls of all components were assigned a velocity of zero (condition "sticking") [9]. Laminar flow is employed as determined from Reynolds numbers calculated using Equation 1. For the 3D models, the pipeline was designed with valves for controlling the open and closed airflow. The open-close valve system is managed through boundary conditions in the simulation. The models of both the basic and modified pipeline are depicted in Figure 5 and Figure 6.



Figure 5. Basic Pipeline 3D Model Pipeline compressor



Figure 6. Modification Pipeline 3D Model Pipeline compressor

3. RESULTS AND DISCUSSION

The computed results of all design variables were analyzed to determine the optimal performance of the pipe. These results were obtained by considering various design variables. The impact of one design variable on other variables was assessed, including the effects on flow rate, pressure, and uniformity profile.

3.1 Pressure Analysis

The pressure field analysis contour displays distinct patterns within the pipeline. However, in the pressure outlet section distribution, both the basic and modified pipeline exhibit the same contour. This configuration is applicable for the modified pipeline. Figures 7 and 8 depict the pressure field, and 9 and 10 depict distribution analyses.

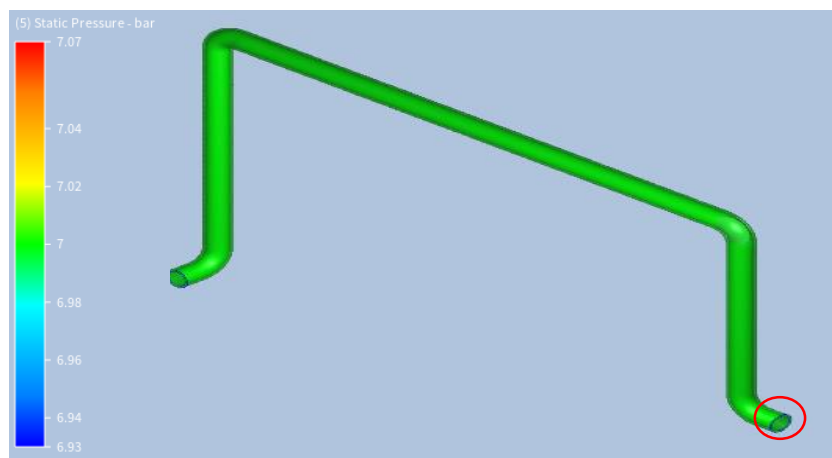

Figure 7. Basic Pipeline Pressure Analysis

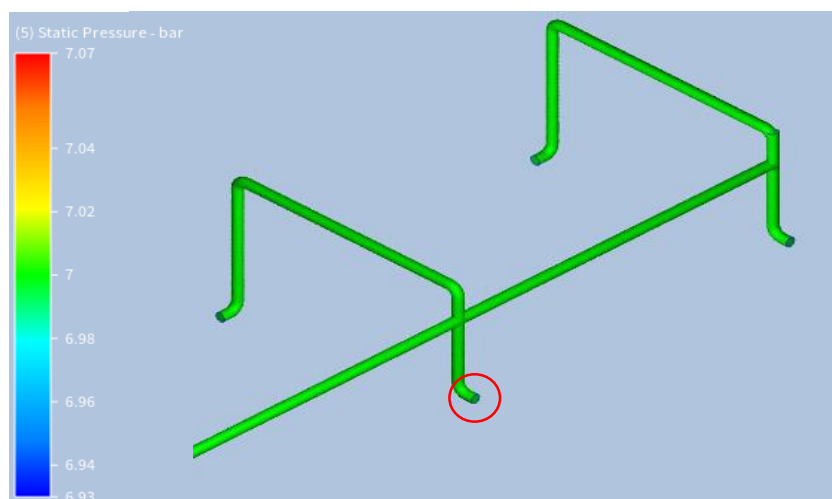

Figure 8. Modification Pipeline Pressure Analysis

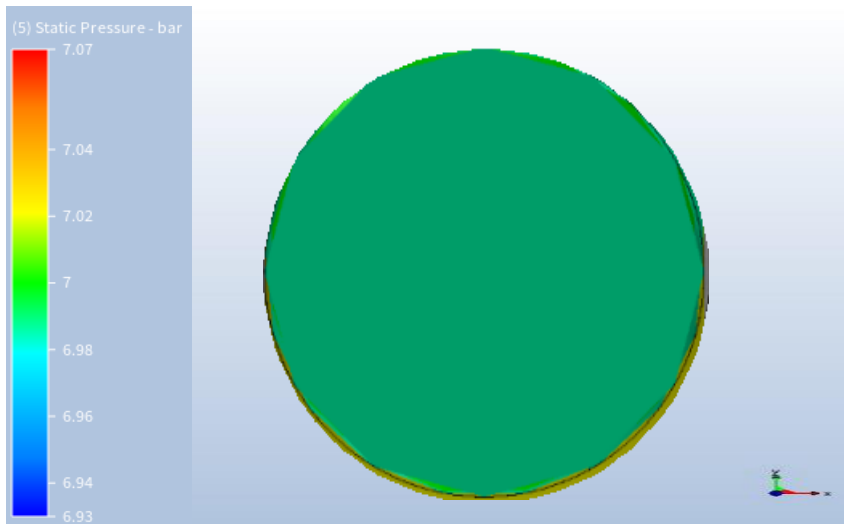

Figure 9. Pressure Outlet Section Distribution Basic Pipeline

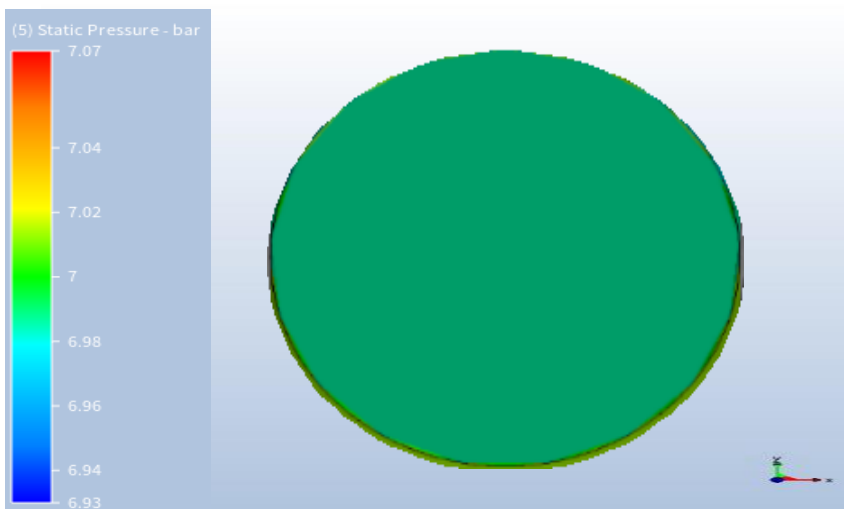

Figure 10. Pressure Outlet Section Distribution Modification Pipeline

Based on the simulation results from the two pipe installation models above, we can see that the pressure has the same value ± 7 bar on the surface and output in both pipes, with the output having a darker color. Evidently, the resultant wind pressure at their outlets is nearly identical. Several factors can account for why these two installation models yield nearly the same output wind pressure. Firstly, the modified pipe installation design lacks any complexities that could impede a substantial reduction in wind pressure, such as changes in elevation and position of the pipe as the airflow begins. Therefore, this factor allows the wind pressure at the modified output pipe to remain compensated [10]. The high speed at which the incoming fluid strikes the pipe also impacts friction losses, which are not consistently significant. This is influenced by several factors, including fluid velocity, the fluid's weight, and its temperature, all of which can affect the pressure at the pipe's outlet, despite engineering and modifications being implemented on the pipe [11].

3.2 Velocity Analysis

The velocity field exhibits identical contours for both pipelines in Figure 11 and Figure 12. However, there is a distinct velocity distribution at the outlet, as depicted in Figure 13 and Figure 14. In the modification pipeline the velocity section distribution reveals multiple contours that correspond to varying values of outlet velocity distribution.

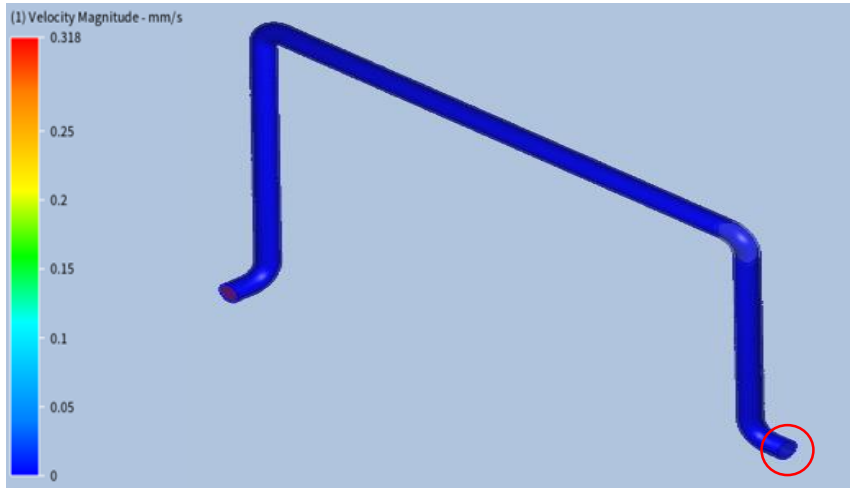

Figure 11. Velocity analysis of Basic Pipeline

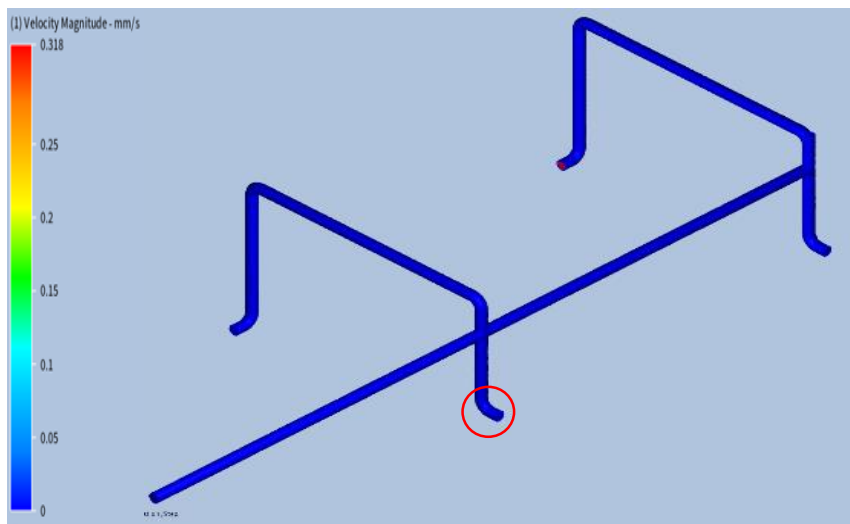

Figure 12. Velocity analysis of Modification Pipeline

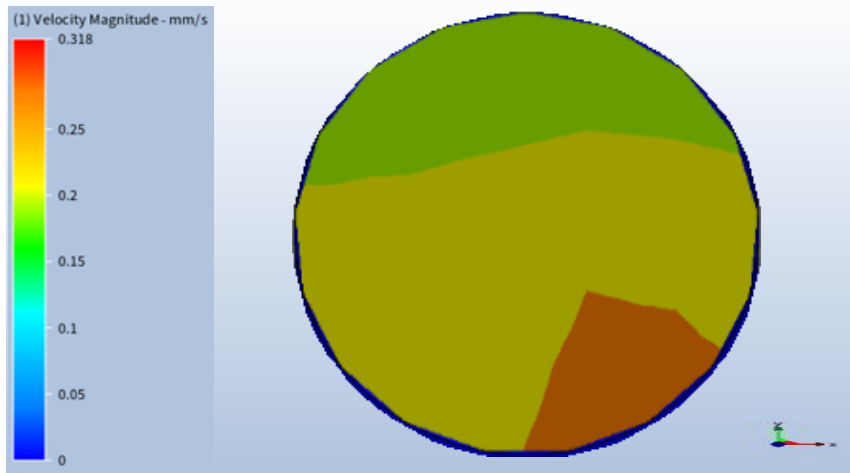

Figure 13. Velocity outlet section distribution of Basic Pipeline

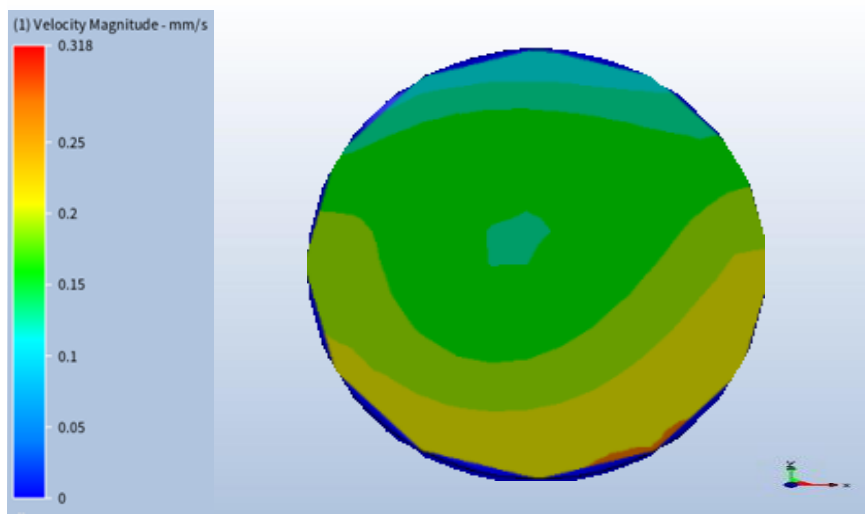

Figure 14. Velocity outlet section distribution Modification Pipeline

In the simulation, the surface of both pipes has a range value of 0 – 5 mm/s but with different output pressures. In the basic pipe, three color contours provide a 0.25 – 0.38 mm/s velocity. For the modification pipe, results show seven contours of color in the range of 0.15 – 0.28 mm/s. The two pipe models exhibit distinct velocity contours regarding the air velocity toward the outlet pipe. Nonetheless, overall, the pipe's surface appears to maintain a consistent velocity contour, as depicted in blue on the isometric image, representing the lowest airflow velocity within the pipe. This phenomenon is a result of the influence of centrifugal force, with the lowest velocity being associated with the region near the tube's wall surface. When centrifugal force is generated, the high-velocity area is consistently observed to be larger towards the center of the pipe [12]. The velocity distribution at the outlet of the basic pipe installation exhibits higher speeds compared to the modified one. This is attributed to the fact that the inlet and outlet pipes share the same direction, minimizing losses due to friction and resistance within the pipe [13]. In modified pipe installations, the airflow velocity exhibits more significant variation. The variation can be attributed to the increased

distance between the inlet and outlet and obstacles such as T-fittings influencing the flow's direction and centrifugal force at the pipe's outlet [14] and [15].

4. CONCLUSIONS

The CFD analysis revealed differences in the pressure field distribution profiles and initial conditions required to achieve the 7 bar outlet pressure. In the modification pipeline, the starting pressure is higher than in the basic pipeline due to factors such as longer pipe lengths and more intricate bend profiles. These aspects contribute to an increased pressure drop. Failing to attain the standard outlet pressure could lead to reduced performance in the pneumatic system of the power plant. Furthermore, the analysis of velocity indicated the presence of numerous secondary flows attributed to the fully developed straight pipe profile at the bend. In the modification pipeline, which features a higher number of bend profiles compared to the basic pipeline, the occurrence of secondary flows is amplified. As the bend angle surpasses 90°, the secondary flow tendencies intensify, leading to greater velocity variations in the outlet section distribution.

REFERENCES

- [1] Prof. D. Vasanthakumar, "Performance analysis and modification of air compressor system," *Int. Res. J. Eng. Technol.*, vol. 02, no. 05, pp. 1171–1175, 2015. [Online]. Available: <https://www.irjet.net/archives/V2/i5/IRJET-V2I5193.pdf>
- [2] Y. Yin, B. Zheng, and X. Zhang, "Experimental investigation on compressed air drying performance using pressurized liquid desiccant," *J. Thermal Sci. Eng. Appl.*, vol. 3937, no. October, 2015, doi: 10.1080/07373937.2015.1057838.
- [3] A. A. Hirani, "CFD simulation and analysis of fluid flow parameters within a Y-shaped branched pipe," *IOSR J. Mech. Civ. Eng.*, vol. 10, no. 1, pp. 31–34, 2013, doi: 10.9790/1684-1013134.
- [4] R. K. Raman, Y. Dewang, and J. Raghuwanshi, "A review on applications of computational fluid dynamics," vol. 2, no. 6, 2017.
- [5] N. Aklis, J. Sedyono, and A. W. Jatmiko, "Pengaruh modifikasi bentuk bodi mobil terhadap pola aliran dengan menggunakan computational fluid dynamics," *Media Mesin: Majalah Teknik Mesin*, vol. 16, no. 2, 2015, doi: 10.23917/mesin.v16i2.1524.
- [6] R. Arya, J. Pratap, S. Chauhan, and I. Khan, "Comparing experimental and simulation results of fluid flow in a pipe system using Solidworks," *Int. Res. J. Mod. Eng. Technol. Sci.*, no. 03, pp. 1042–1045, 2023, doi: 10.56726/irjmets34299.
- [7] I. W. Yudhatama, M. I. P. Hidayat, and W. Jatimurti, "Simulasi computational fluid dynamics (CFD) erosi partikel pasir dalam aliran fluida gas turbulen pada elbow pipa vertikal-horizontal," *Tek. ITS*, vol. 7, no. 2, pp. 134–139, 2018.
- [8] S. K. Sreekala and S. Thirumalini, "Study of flow performance of a globe valve and design optimisation," *J. Eng. Sci. Technol.*, vol. 12, no. 9, pp. 2403–2409, 2017.
- [9] J. A. M. Eng, Y. B. Shinger, and T. Ag, "Journal of Applied," vol. 4, no. 2, 2015, doi: 10.4172/2168-9873.1000158.
- [10] E. Shashi Menon, *Pressure Required to Transport*, 2015, doi: 10.1016/b978-1-85617-830-

3.00006-7.

- [11] S. Lubis, C. A. Siregar, and F. Abdilah, "Simulation of air flow loss in triangle pipe construction," *IOP Conf. Ser. Mater. Sci. Eng.*, vol. 821, no. 1, pp. 0–5, 2020, doi: 10.1088/1757-899X/821/1/012047.
- [12] E. Mahmoudi, L. Y. Ng, W. L. Ang, Y. T. Chung, R. Rohani, and A. W. Mohammad, "Enhancing morphology and separation performance of polyamide 6,6 membranes by minimal incorporation of silver decorated graphene oxide nanoparticles," *Sci. Rep.*, vol. 9, no. 1, pp. 1–16, 2019, doi: 10.1038/s41598-018-38060-x.
- [13] J. W. Lim, N. Narendran, C. E. Chai, and M. I. N. Ma'Arof, "A review on the air flow behaviour in the intake pipe," *IOP Conf. Ser. Mater. Sci. Eng.*, vol. 854, no. 1, 2020, doi: 10.1088/1757-899X/854/1/012010.
- [14] A. Jonuskaite, "Flow simulation with SolidWorks," 2017, doi: 10.1046/j.1601-183X.2003.00040.
- [15] J. Smith, *Fluid Mechanics and Pipe Design*, 3rd ed. New York, NY, USA: Wiley, 2018, pp. 102–110.